

FSW50 Pallet Wrapping Machine

OPERATION MANUAL



Machine	Semi-Automatic Pallet Wrapping Machine
Model	FSW50
Date	February 2018
Issue	FPA002

CONTENTS

1. General Information	3
1.1 Note of installation	3
1.2 Notice of Operation	3
2. Specification	4
2.1 Machine Dimensions	5
3. Safety Precautions	6
4. Operation of the Control Panel	7
4.1 Control Button Explanations	8
4.2 User Panel	10
5. Film Loading and Threading	11
5.1 Pre Stretch Percentage Change	12
6. Suggested Maintenance and Trouble Shooting	13
6.1 Suggested Maintenance	13
6.2 Warranty Periods	13
6.3 Fromm Service Solutions	13
6.4 Possible troubleshooting causes and remedies	14
7. Contact Fromm Packaging	15

1. GENERAL INFORMATION

Congratulations on the purchase of your Fromm Pallet Wrapping Machine. We trust you will have many years of packaging efficiency.

Before proceeding with the operation or installation of your new machine please read this manual thoroughly and gain a full understanding of the requirements, features and operation of your new machine.

1.1 Note of Installation

To ensure your machine operates in a safe manner please review the following requirements:

1. Machine standard power is 240V (+- 10%).
2. Machine standard power Hertz is 50Hz. (+- 2%).
3. Machine can operate in temperatures between 0°C - 45°C.
4. The position where you place the machine must be flat and have no vibrating machines around the wrapping machine.
5. Please ensure you download and read our Install Guide before attempting it yourself.

1.2 Notice of Operation

Before you start using the wrapping machine, please review the following conditions:

1. Before operating, please read the machine operational manual carefully.
2. Make sure there is no object put on the power cable.
3. Make sure there is no object put on the upper elevator unit.
4. Avoid any damp object or water around the electric parts.
5. Do not stand on or across from the machine during operation.
6. When a problem does occur, please check the troubleshooting section for more information and advice.

2. SPECIFICATION

Maximum Machine Size

Dimension: 2973 mm (L) x 1880 mm (W)

Mast Height: 2345mm

Turntable Height from Floor: 87mm

Shipping weight: 664 Kgs.

Electrical Data

240Volt, 50Hz, 1 Phase

Power Consumption: 1.2 KW

Production Capacity

Spiral: 30 – 40 loads per hour

Turntable Maximum Speed: 12 RPM

Maximum Load: 1.2 M (wide) x 1.2 M (long) x 2M (height)

1.8M Maximum Wrap Diagonal

Max. Load Weight: 2000 kg

2.1 Machine Dimensions

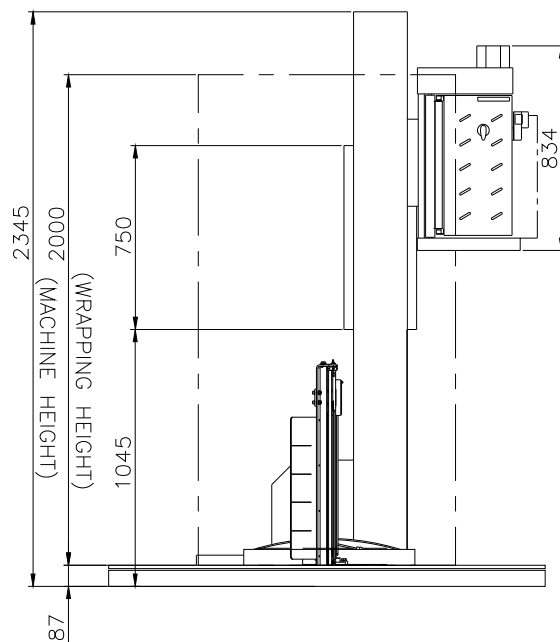
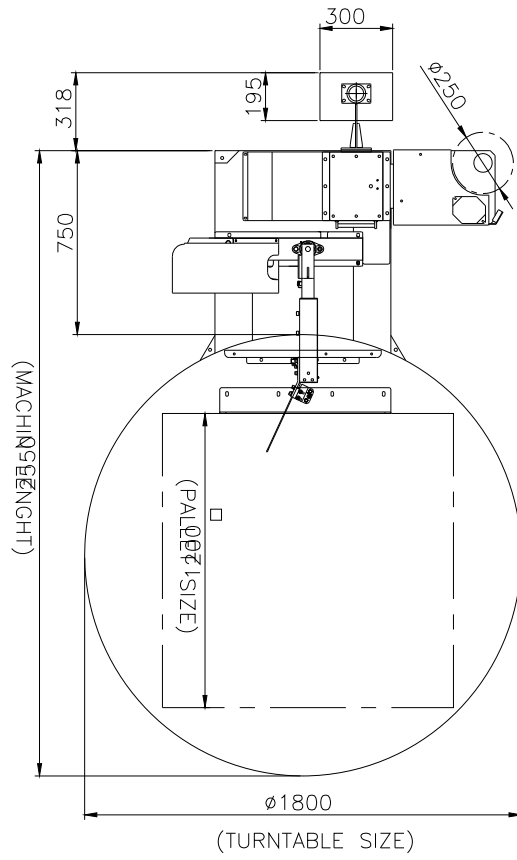

3. SAFETY PRECATIONS

1. Read the Operation Manual before operating the machine.
2. Do NOT attempt to service the machine unless you are qualified.
3. Loose clothing must NOT be worn while the machine is in operation.
4. Stay clear of moving parts while the machine is in operation.
5. Push in the EMERGENCY STOP bottom when replacing each roll of stretch film, threading the Pre-Stretch System, performing maintenance, cleaning up, and when the machine is not in use.
6. Do NOT attempt to wrap product that the machine is not designed to wrap.
7. Do NOT stand on the Film Carriage.
8. Do NOT remove or modify the fixed lower and upper limit switch stops. This may cause personal injury and/or damage to the machine.

4. OPERATION OF THE CONTROL PANEL

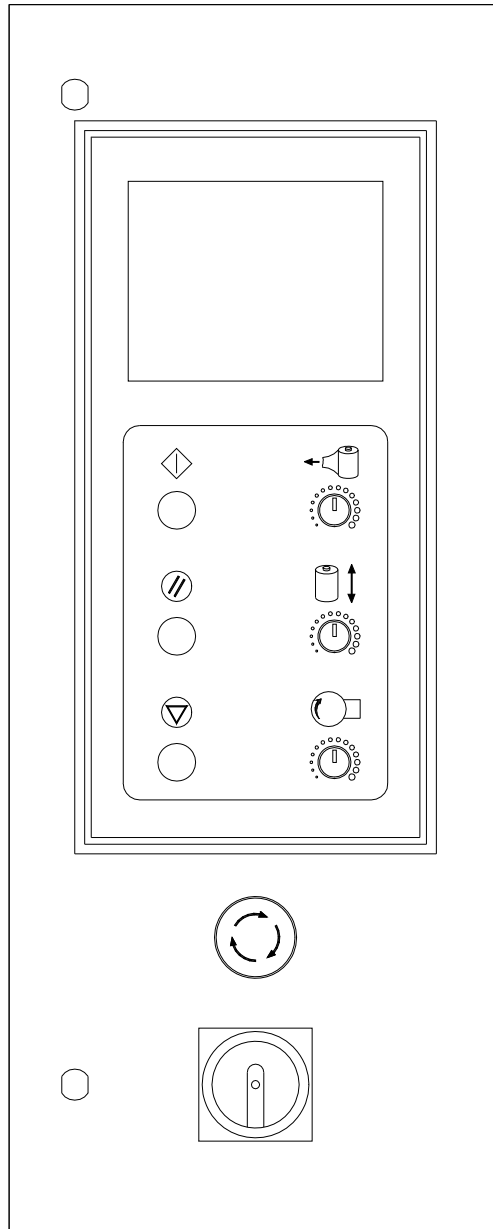

4.1 Control Button Explanations



START BUTTON

Press this button to start operation.



Note: After all functions have been reset press this button to start the program



RESET BUTTON

Pressing the button, all operation is released and the machine returns to natural status.

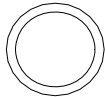

PAUSE BUTTON

Press the button; the machine will be stop whether it is under automatic or manual mode. Press the START button to complete the rest program.

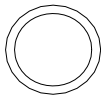

FILM TENSION ADJUSTMENT

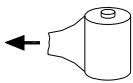

It is the control knob for wrapping tension.

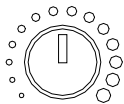

Turn the knob clockwise to increase the tension.

Turn the knob counter-clockwise to decrease the tension.

NOTE: 1. Turntable speed and wrap tension can be adjusted individually.

2. Wrapping tension on the package edge and side are the same.

3. After setting the wrapping tension, it is suitable for most packages and no need to make adjustments.

ELEVATOR SPEED ADJUSTMENT

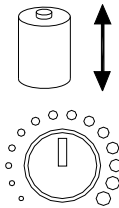

Turn the knob clockwise to increase the speed of elevator.

Turn the knob counter-clockwise to decrease the speed of elevator.

The speed adjust knob is available for both “AUTO” and “MANU” program.

TURNTABLE SPEED ADJUSTMENT

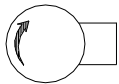

Turn the knob clockwise to increase the speed of turntable.

Turn the knob counter-clockwise to decrease the speed of turntable.

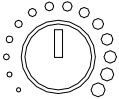

The speed adjust knob is available for both “AUTO” and “MANU” program.

If there is no particular requirement, please set the knob on standard position.

The turntable speed is 12 RPM.

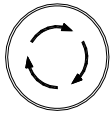

EMERGENCY STOP

Press this button for any emergency situation.

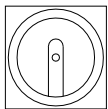

MAIN POWER

This turns power OFF or ON.

4.2 User Panel

TIMER HELP SCREEN 1

TABLE DECEL START DELAY - Sets the point where the rotation (turntable) changes from fast to slow speed.

HOT WIRE EXTEND TIMER - Sets the time duration for the hot wire when cutting the film.

WIPER ARM RETRACT DELAY - Sets the time delay after the package clears the pack detection sensor. The wiper arm will retract to home position.

TIMER HELP SCREEN 2

CARRIAGE UP STOP DELAY – Sets the time delay to stop the carriage at top of product height.

FILM JAWS OPEN DELAY – Sets the delay for the clamps to release the film after wrap.

FILM OFF DELAY – Sets the time delay for film stop out from the carriage.

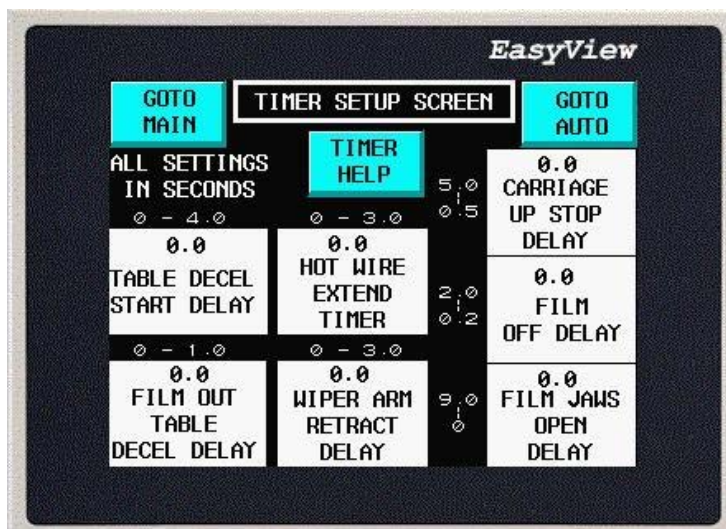

5. FILM LOADING AND THREADING

1. Open access door.
2. Load the film roll onto the film roll holder, and make sure the roll is securely in place.
3. Pull out the film manually, and thread it through dancing bar "C"; ensure enough length to reach the film clamp device when it's closed.
4. Place film loosely between door and pre-stretch rollers, then close the door and ensure that the door is correctly locked.

See Figure 1. Film Loading

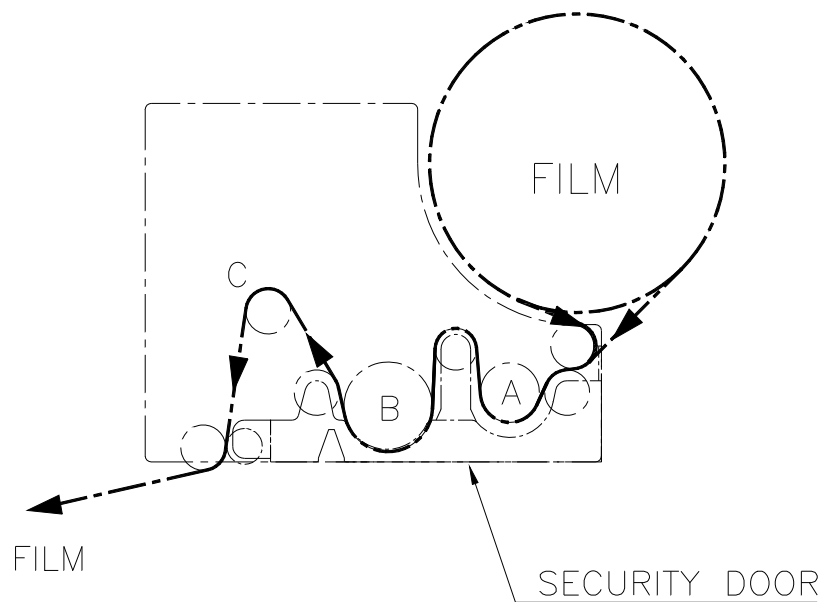

5.1 Pre-Stretch Percentage change

The standard gears on the FSW50 is set to perform 230% or 300% pre-stretch ratio.

To change different ratio, please follow the instructions below.

200% & 250% pre-stretch ratio is also available, please consult your supplier for details.

1. Switch the power off and remove the handle cover

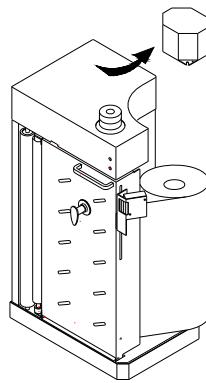

2. Press the safety lock inward, and use the handle to adjust the pre-stretch ratio.
3. Pull up the handle for High Pre-Stretch ratio or push down to get Low Pre-Stretch ratio.

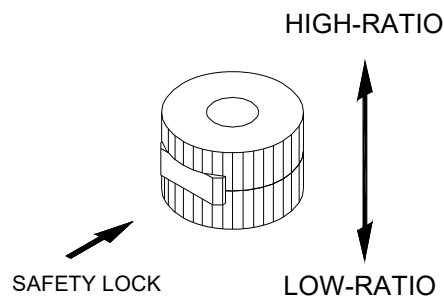

4. Before the machine is switched on, please ensure the SAFETY LINE is back to its home position, and the indicator lamp is shown correctly. Re-fit handle cover.

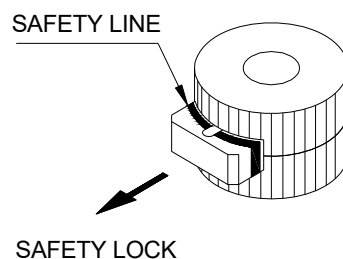

6. SUGGESTED MAINTENANCE & TROUBLE SHOOTING

6.1 Suggested Maintenance

Fromm Packaging Australia recommends servicing every six months as a minimum, but many machines have different service intervals depending on condition and throughput. It's best to discuss your servicing requirements with Fromm Packaging.

6.2 Warranty Periods

To provide you with peace of mind all Fromm stretch wrapping, strapping and carton taping equipment includes a two year warranty from the date of delivery to your site. The warranty includes all deficiencies clearly resulting from poor manufacturing or faulty materials. Damage claims as a result of production shutdowns and claims for damage to persons and to property resulting from warranty deficiencies covering structural components and non-wearing parts effective from the date of delivery to your site.

The warranty excludes:

- Wearing parts (rollers, motors and belts),
- Deficiencies resulting from improper installing, incorrect handling and maintain the equipment,
- Disregard of directions in the operation manual,
- Unauthorized repair work to the equipment,
- Use of consumable products not recommended by the supplier of the equipment.

We reserve the right to modify the product any time in order to improve the quality.

6.3 Fromm Service Solutions

Fromm service technicians are trained to service all stretch wrapping, strapping and carton taping machines which we sell and are your on-site expert support to optimise the performance and reliability of your packaging equipment.

With technical offices in Sydney, Brisbane and Melbourne metro areas we are on hand to ensure your equipment is running smoothly. Customers located outside metropolitan areas we offer phone support and can organise onsite technical support when required.

6.4 Possible Troubleshooting Causes and Remedies

Turntable belt adjustment

Please refer to illustration 5-1, and then loosen the motor seat M10 screw 4 pcs.

Turn the (M10) on the seat until get enough tension. Turn and tight the motor seat screw 4 pcs again.

Elevator unit driving chain adjustment

Please refer to illustration 5-2, remove mast covers and check for proper tension to the drive chain. Adjust if necessary.

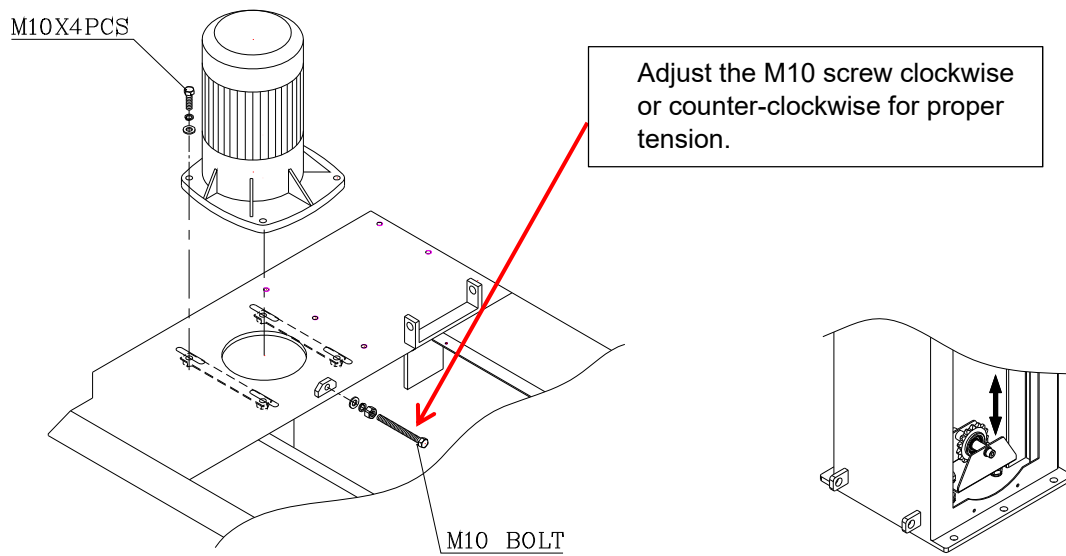

FIG. 5-1

FIG. 5-2

7. CONTACT FROMM PACKAGING AUSTRALIA

For any questions please contact Fromm Packaging Australia

Phone: 1800 023 890

Email: info@fromm-pack.com.au

Postal Address: PO Box 4016, Mt Ommaney QLD 4074